

# 产品规格书

方形锂离子电池

型号：L173F163

## 修订履历

版次	日期	变更内容	备注
A0	2021.04.13	初始状态	
A1	2021.10.29	将 4.1 扭矩强度：相切于极柱圆柱面 XY 方向最大 6Nm 更改为 12Nm。	
A2	2022.01.20	1) 将 4.1 扭矩强度：相切于极柱圆柱面 XY 方向最大 12Nm 更改为 9Nm； 2) 增加 4.2 可施加在极柱上的最大深度； 3) 修订公司名称、Logo，2.3.3 补充 ACR 信息。	

编制	校对	审核	批准	会签
种传广 2022.1.20	李彦龙 2022.1.20	单旭意 2022.1.20	曹勇 2022.1.20	万许东 2022.1.20



# 产品规格书

# Product Specification

方形锂离子电池

Prismatic lithium Ion Battery

型号: L173F163

Model: L173F163

中创新航科技股份有限公司  
**CALB Co., Ltd.**

## 目录 Content

1. 介绍 INTRODUCTION .....	1
1.1. 目的 Purpose.....	1
1.2. 保密 Confidentiality .....	1
1.3.坐标系 Coordinate System .....	1
2. 电池信息 CELL DATA.....	2
2.1. 产品识别 Cell Identification .....	2
2.2. 结构信息 Structure Data .....	2
2.3. 电性能数据 Electrical Performance Data .....	6
3. 电池工作以及安全限制 OPERATION AND SAFETY LIMIT ON CELL LEVEL .....	12
3.1. 电压限制 Voltage limit .....	12
3.2. 电流限制 Current Limit.....	12
3.3. 温度限制 Temperature Limit .....	14
4. 模组设计以及过程注意事项.....	15
PARAMETER FOR MODULE DESIGN AND PROCESS .....	15
4.1. 可施加在极柱上的最大扭矩 Max Torque which can be applied to terminal.....	15
4.2. 可施加在极柱上的最大力 Max. Force which can be applied to terminal .....	15
4.3. 堆叠模组时大面挤压力 Large surface extrusion when stacking modules.....	15
4.4. 膨胀力 Swelling Force .....	15
4.5. 模组焊接过程中温度的影响 Effect of Heat for Module Welding .....	16
5. 危险警告、潜在故障 Hazard Warnings, Potential Faults.....	18
5.1. 发生意外时的行动 Action in the Accidents.....	20
5.2 电池存储 Cell Storage.....	20
5.3 注意事项 Attention.....	20
5.4 注意和禁止事项 Caution and Prohibition.....	21
附录 Appendix.....	25

## 1. 介绍 INTRODUCTION

### 1.1. 目的 Purpose

本文件主要介绍了中创新航生产的锂离子动力电池的产品特性以及使用规范。

This document describes the characteristics and handling information of the rechargeable lithium-ion cell manufactured and supplied by CALB Co., Ltd.

### 1.2. 保密 Confidentiality

本文件所载信息仅供授权的个人或实体使用，内含涉密信息。任何针对本文件内容的披露、复制、分发或其他行为都是严格禁止的，甚至是非法的。

The information contained in this document is intended solely for the use of the individual or entity that is authorized to receive it. It contains confidential or privileged information. Any disclosure, copying, distribution or taking an action in reliance on the contents of this document is strictly prohibited and may be unlawful.

### 1.3. 坐标系 Coordinate System

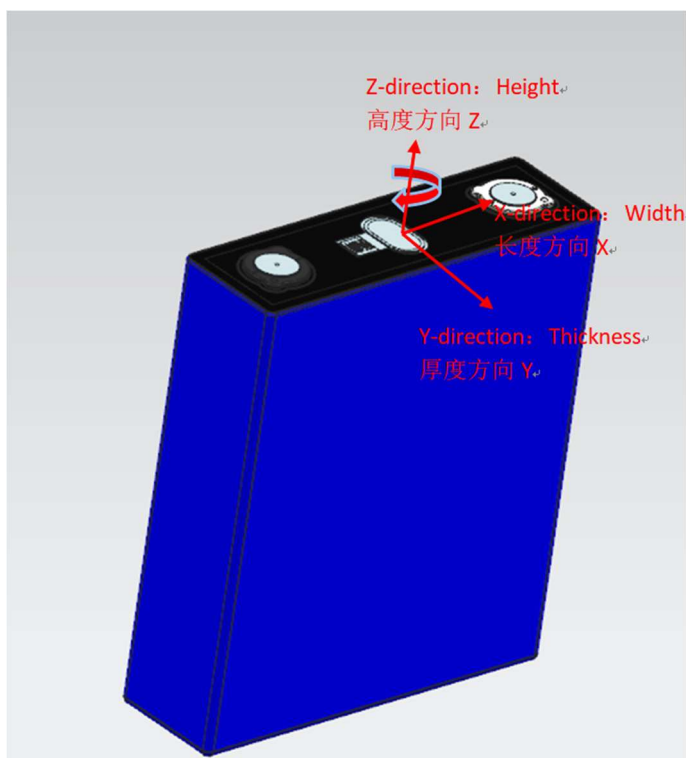

## 2. 电池信息 CELL DATA

### 2.1. 产品识别 Cell Identification

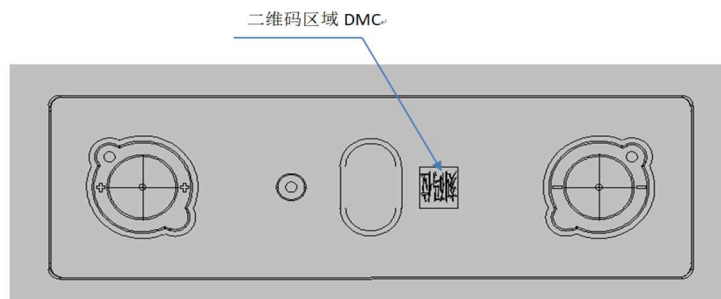

电池顶部的盖板表面上同时有二维码和编码，其信息一致。

The DMC code and ID numbers imply the same information and both are inscribed on the cap plate.

#### 2.1.1 正负极极柱区分 Identification of Positive and Negative Terminal

符号“+”表示正极极柱，符号“-”表示负极极柱。

The symbol "+" indicates the positive pole, and the symbol "-" indicates the negative pole.

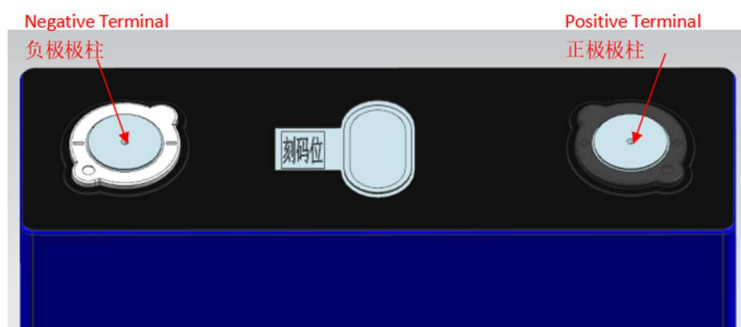

### 2.2. 结构信息 Structure Data

#### 2.2.1. 单体电池尺寸 Cell Dimensions

项目 Item	数值 Value	备注 Remark
电池长度 x 厚度 x 高度 /mm Cell Length x Thickness x Height /mm	(174.4±0.3) x (36.4±0.15) x 230.5±0.6), 含极柱 (with terminal)  (174.4±0.3) x (36.4±0.15) x (217.3±0.5), 不含极柱(without terminal)	厚度尺寸测量条件: 20%SOC, 300±20 kgf Measurement conditions for thickness dimensions: 20%SOC, 300±20 kgf
电池重量/kg Cell Weight/kg	3.19±0.16	/
电池体积/L Cell Volume/L	1.38, 不含极柱(without terminal)	/

## 2.2.2. 电池外观 Cell Image

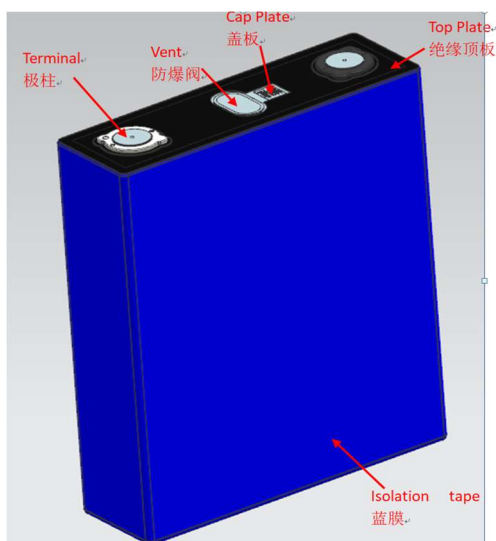

## 2.2.3. 电池表面信息 Cell Surface Condition

电池侧面和底部小部分区域为 PET 绝缘膜覆盖（蓝色）；

电池顶部除了防爆阀、二维码、正负端子外，均被 PC 绝缘盖板覆盖。

Cell side surface is covered with PET insulation tape (blue color);

Cell top surface is covered with PET except vent, code and rivet terminal.

### 2.2.3.1 工作环境清洁度 Cleanliness of Work Environment

在模组以及 pack 装配过程中，应根据汽车工业标准（ISO/TS 16949）执行清洁计划。

A technical cleanliness plan should be executed according to automotive industry standards (ISO/TS 16949) in the process of module and pack assemble.

### 2.2.3.2 电池清洁 Cell Cleaning

在模组或 pack 装配前，应当对电池表面进行清洁处理，确保移除电池表面异物。

Cell should be cleaned after the arrival at customer and before module and pack assembly in order to remove foreign matter on the cell surface.

## 2.2.4. 二维图纸 2D Drawing

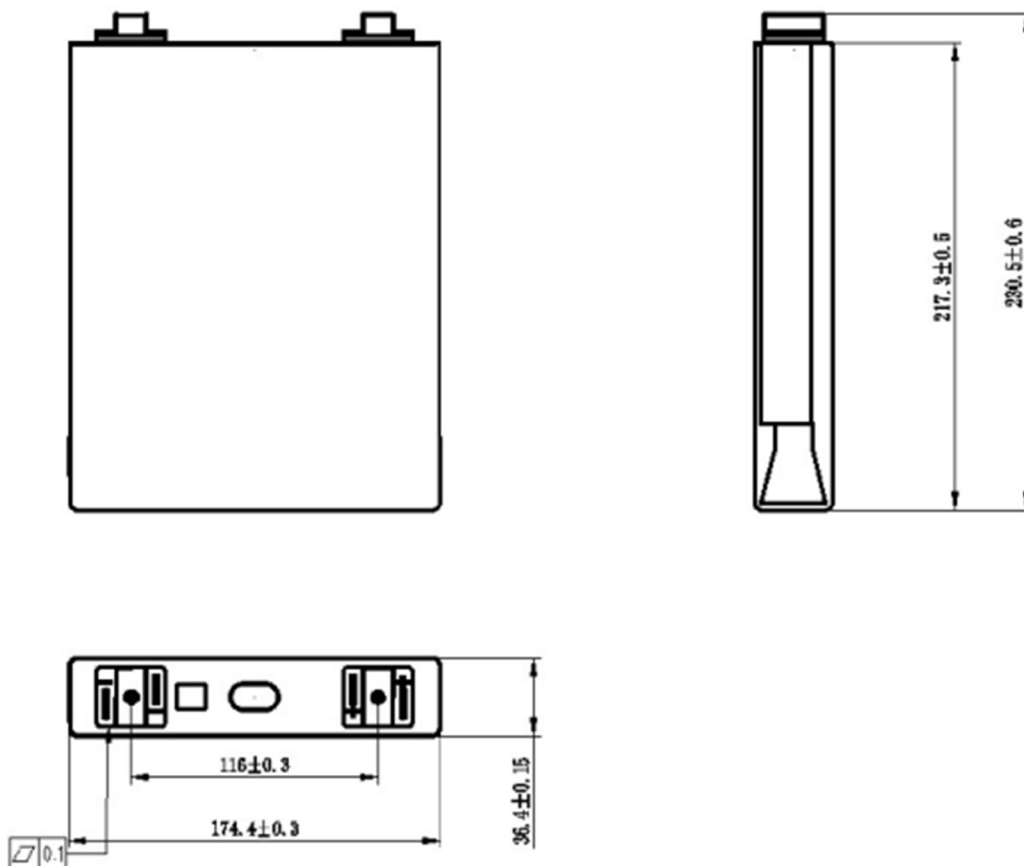

## 2.2.5. 爆炸图 Exploded Diagram

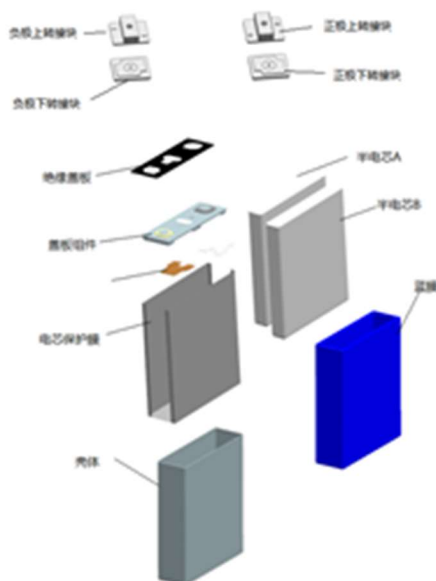



## 2.2.6. 零部件设计 Part Design

### 2.2.6.1. 壳体 Can

零部件 Parts	材质 Material
壳体 Can	Al3003 H14

### 2.2.6.2. 绝缘膜 Insulation Tape

零部件 Parts	材质 Material
绝缘膜 Insulation tape	PET 颜色(Color): 蓝色(Blue) 厚度(Thickness): 0.11 mm

### 2.2.6.3. 正负极极柱 Positive and Negative Terminal

1) 材质: 正极柱(Al 1060 H14), 负极柱(Al 1060 H112 & Cu T2)

Material: Positive terminal (Al 1060 H14), Negative terminal (Al 1060 H112 & Cu T2)

2) 电池外观 Cell Appearance

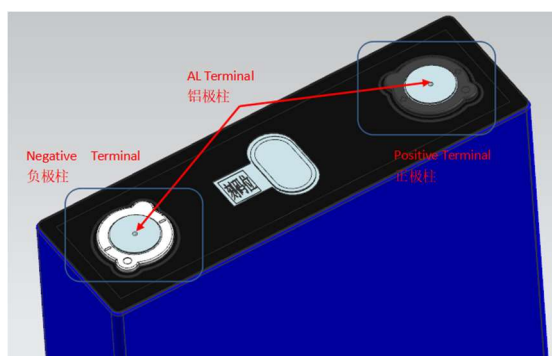

### 2.2.6.4. 绝缘顶板 Top Insulation Film

零部件 Parts	描述 Description
绝缘顶板 Top insulation film	材料: PC, 厚度: 0.325 mm Material: PC, Thickness: 0.325 mm

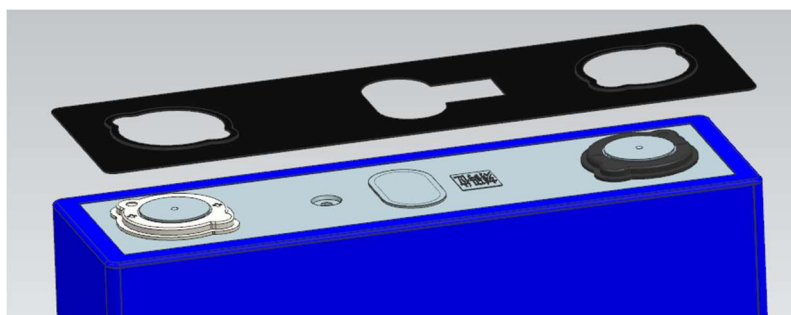

## 2.3. 电性能数据 Electrical Performance Data

### 2.3.1 容量 Capacity

标准容量 Standard capacity: 163 Ah (1C discharge, 25°C)

### 2.3.2. 功率 Power

Temperature		Power [W]						Max current
		Duration time	90% SOC	50% SOC	30% SOC	20% SOC	10% SOC	
25°C	Discharge	30sec	779.00	765.75	759.50	748.50	730.25	250 A
		60sec	776.5	762.75	754.25	742.50	720.75	250 A
	Charge	30sec	908.75	889.00	883.00	876.50	863.00	250 A
		60sec	797.72	892.00	885.00	879.75	866.50	250A
45°C	Discharge	30sec	788.00	775.50	769.00	758.50	745.00	250 A
		60sec	787.00	774.00	765.75	755.25	741.00	250 A
	Charge	30sec	892.25	877.00	872.00	867.75	854.50	250A
		60sec	895.75	879.00	873.00	869.25	857.50	250 A

### 2.3.3. 内阻 DC-IR

Temperature		DC-IR /mΩ				
		Duration time	90% SOC	50% SOC	30% SOC	20% SOC
25°C	Discharge	10sec	0.751	0.802	0.871	0.916
		30sec	0.820	0.871	0.957	1.008
	Charge	10sec	0.988	0.849	0.791	0.781
		30sec	1.157	0.980	0.892	0.888

Temperature	ACR /mΩ (Ac. 1kHz)
	20% SOC, 新鲜电池
25°C	0.2~0.5

## 2.3.4. 开路电压 OCV

Temp.	OCV (V)											
	SOC%	100	90	80	70	60	50	40	30	20	10	0
25°C	Discharge	3.406	3.302	3.300	3.295	3.269	3.261	3.255	3.242	3.210	3.161	2.500
	Charge	3.648	3.388	3.381	3.375	3.356	3.341	3.337	3.334	3.307	3.257	2.600

## 2.3.5. 安全测试 Safety Test Results

项目 Item	测试条件 Test condition	EUCAR Level	备注 Remark
机械滥用 Mechanical Abuse	挤压 Crush 1) 挤压力达到 200 kN 或电池形变量达到 30%或电压为 0 V; 1) 200 kN of extrusion or 30% of cell deformation or 0 V of cell voltage; 2) 挤压方向:垂直于蓄电池盖板方向施压; 2) Crush Direction: Press vertically in the direction of extrusion plate; 3) 挤压速度:5±1 mm/s。 3) Crush Speed: 5±1 mm/s.	Level 2	<EUCAR safety level > Level 0: No effect Level 1: Passive protection activated Level 2: Defect/Damage Level 3: Leakage, Δ mass < 50% Level 4: Venting, Δ mass > 50% Level 5: Fire or Flame Level 6: Rupture Level 7: Explosion
	针刺 Nail Penetration 1) 100% SOC, φ5 ~ φ8 mm 的耐高温钢针以 (25±5) mm/s 的速度, 从垂直于电池极板的方向贯穿, 贯穿位置宜靠近所刺面的几何中心, 钢针停留在电池中, 观察 1 h。 1) 100% SOC, penetrate the battery from the vertical direction throughout the inside plates with φ5 ~ φ8 mm needle at (25 ± 5) mm/s speed (needle stays in the battery) and observe 1 h.	Level 4	
	振动 Vibration Test 1) 将测试对象安装在振动台上; 1) Install the test object on the vibration table; 2) 对 XYZ 三个方向每个方向施加振动 8 h, 振动测试参数按照表 5 进行, 振动曲线如图 6, 同时叠加一个温度工况, 温度参数见图 7; 2) Vibration is applied to each of the three directions of XYZ for 8 h. Vibration test parameters are carried out in accordance with Table 5. The vibration curve is shown in Figure 6, a temperature condition is superimposed, and the temperature parameters are shown in Figure 7. 3) 振动结束后静置 1h; 3) Stand for 1h after the vibration is over; 4) 以标准电流对电池进行标准循环 3 次, 确定振动后容量; 4) Conduct standard cycle for the cell for 3 times with standard current to determine the capacity after vibration;	Level 2	

		<p>5) 按照标准测试方法测试电池内阻值。</p> <p>5) Test the cell resistance according to the standard test method.</p>		
	热稳定性 Thermal Stability	<p>1) 100% SOC, 5°C/min 的升温速率从 25°C加热到 130°C, 然后保持 30 分钟。</p> <p>1) 100% SOC, heat from 25°C to 130°C at a heat rate of 5°C/min and stay 30 min.</p>	Level 2	
热滥用 Thermal Abuse	热失控 Thermal Runaway	<p>1) 加热装置选用平面状或棒状, 表面应覆盖陶瓷、金属或绝缘层, 加热装置功率要求见表 3, 加热装置应与蓄电池直接接触, 加热装置的尺寸规格应不大于测试对象的被加热面, 监测点温度传感器布置在远离热传导的一侧, 即安装在加热装置的对侧(如图 4)。</p> <p>1) Heating device shall be flat or rod-shaped, and the surface shall be covered with ceramic, metal or insulating layer. The power requirements of the heating device are shown in Table 3. The heating device shall be in direct contact with the battery. The size of the heating device shall not be larger than the heated surface of the test object. The temperature sensor of the monitoring point shall be arranged on the side far away from the heat conduction, that is, the opposite side of the heating device (as shown in Figure 4).</p> <p>2) 单体电池充电到 100%SOC 后, 再用 1C 电流继续充电 12 min;</p> <p>2) Cell was charged to 100%SOC, and continually charged for 12 min with 1C current;</p> <p>3) 立刻启动加热装置, 并以其最大功率对测试对象进行持续加热;</p> <p>3) Start the heating device immediately and heat the test object continuously with its maximum power;</p> <p>4) 当发生热失控或者定义的监测点温度达到 300 °C时, 停止触发, 关闭加热装置;</p> <p>4) When thermal runaway occurs or the temperature of the defined monitoring point reaches 300 °C, stop triggering and turn off the heating device;</p> <p>5) 是否发生热失控的条件按照如下规则判定:</p> <p>5) Whether there is thermal runaway shall be determined according to below:</p> <p>(1) 测试对象产生电压降超过初始电压的 25%;</p> <p>(1) The voltage drop of cell is more than 25% initial voltage;</p> <p>(2) 监测点温度达到电池制造商规定的最高工作温度;</p> <p>(2) The temperature of the monitoring point reaches the maximum working temperature specified by the battery manufacturer;</p> <p>(3) 监测点的温升速率达到 <math>dT/dt \geq 1^\circ\text{C/s}</math>, 且持续 3s 以上。</p> <p>(3) The temperature rise rate of the monitoring point reach <math>dT/dt \geq 1^\circ\text{C/s}</math> for more than 3s.</p> <p>当(1)和(3)或者(2)和(3)发生时, 判定发生热失控。如果未发生热失控, 试验通过。加热过程中及加热结束 1 h 内, 不起火、</p>	Level 4	

		<p>不爆炸则试验通过。上述结论应在不拆卸测试样品的前提下通过肉眼来进行判断。</p> <p>When (1) and (3) or (2) and (3) occur, thermal runaway is determined. If no thermal runaway occurs, the test passes. During the heating process and within 1 h after the heating, if there is no fire or explosion, the test will pass. The above conclusion should be judged by naked eyes without disassembling the test sample.</p>	
电滥用 Electrical Abuse	过充 Overcharge	<p>1) 100% SOC, 1C 恒流充电至截止电压的 1.5 倍时停止充电, 观察 1 小时。</p> <p>1) 100% SOC, 1C constant current charge to 1.5 times of the cut-off voltage, quit charging and observe 1 h.</p>	Level 4
	过放 Over Discharge	<p>1) 100% SOC, 1C 恒流放电 1.5 小时, 观察 1 小时。</p> <p>1) 100% SOC, 1C constant current discharge 1.5 h and observe 1 h.</p>	Level 2
	外短路 External Short Circuit	<p>1) 100% SOC, 电池外短路 10 min, 短路电阻小于 5 mΩ, 观察 1 小时。</p> <p>1) 100% SOC, 10 min of cell external short circuit and the external short circuit resistance is less than 5 mΩ, observe 1 h.</p>	Level 2

## 2.3.6. 环境类测试结果 Environmental Test Results

项目 Item	测试条件 Test Condition	测试结果 Test Result
跌落测试 Drop Test	1) 100% SOC, 电池正负端子向下从 1.5 m 高度处自由跌落到水泥地面上, 观察 1 小时。 1) 100% SOC, two terminals of cell faces down from a height of 1.5 m onto the cement floor and observe 1 h.	Level 2
温度循环 Temperature Cycle	1) 100% SOC, 单体电池放入温度箱中, 温度箱温度按照表 1 和图 2 进行调节, 循环次数 5 次, 观察 1 小时。 1) 100% SOC, cell was put into the temperature box, and temperature of the temperature box was adjusted according to table 1 and figure 2 for 5 cycles, and observe 1 h.	Level 2
低气压 Low Pressure	1) 100% SOC, 单体电池放入低气压箱中, 调节试验箱中气压为 11.6 kPa, 温度为室温, 静置 6 小时, 观察 1 小时。 1) 100% SOC, cell was put into a low-pressure chamber, air pressure was adjusted to 11.6 kPa in ambient temperature, stand for 6 h and observe 1 h.	Level 2
海水浸泡 Seawater Immersion	1) 100% SOC, 将单体电池浸入 3.5% NaCl 溶液 (质量分数) 中 2 小时, 水深应完全没过单体电池, 观察 1 小时。 1) 100% SOC, cell was immersed in 3.5% (mass fraction) NaCl solution for 2 h, water depth should completely exceed height of the cell and observe 1 h.	Level 2

## 2.3.7. 寿命测试结果 Life Test Result

	测试条件 Test Condition	结果 Results
充电/放电循环 Charge/discharge Cycle	充电：在恒温箱以 1C 恒流持续充电至 3.65 V，然后在 3.65 V 下恒压持续充电直至电流小于 0.05 C。 Charge: 1C constant current charge to 3.65 V, and constant voltage charge till charge current is less than 0.05C in thermotank. 放电：以 1C 恒流持续放电至 2.5 V。 Discharge: 1C constant current discharge to 2.5 V.	>4000 cycles (25°C) >2000 cycles (45°C)

## 3. 电池工作以及安全限制 OPERATION AND SAFETY LIMIT ON CELL LEVEL

### 3.1. 电压限制 Voltage limit

充放电电压限制 Voltage limit of charge and discharge			
限制 Limit	项目 Item	数值 Value	备注 Remark
安全限制 Safety limit	充电电压 Charging voltage	3.8 V	/
	放电电压 Discharging voltage	1.8 V	/
工作限制 Operation limit	充电电压 Charging voltage	3.65 V	/
	放电电压 Discharging voltage	2.0 V (T≤0℃) 2.5 V (T>0℃)	/

工作电压以及安全限制电压和模组或者 pack 中的最低温度为准。

Operation voltage and safety voltage limit is applied depending on the minimum module temperature.

### 3.2. 电流限制 Current Limit

#### 3.2.1. 最大放电电流 Discharge Operation Current Limit

温度 Temperature (°C)	最大放电电流 Discharge Operating Current Limit			
	峰值限制 Peak Current Limit		持续限制 Continuous Current Limit	
	持续时间 Duration (sec)	$I_{max\_peak}$ (A)	持续时间 Duration (sec)	$I_{max\_continuous}$ (A)
55	30	163	持续	82
50	30	163	持续	82
45	30	245	持续	163
40	30	245	持续	163
35	30	245	持续	163
30	30	245	持续	163
25	30	245	持续	163
20	30	245	持续	163
15	30	245	持续	163
10	30	245	持续	163
5	30	245	持续	82
0	30	245	持续	49
-5	30	163	持续	49
-10	30	163	持续	49
-15	30	122.3	持续	33
-20	30	122.3	持续	33
-25	30	82	持续	25
-30	30	82	持续	25



## 3.2.2 充电电流限制 Charge operation current limit (only charge direction)

温度 Temperature (°C)	充电电流限制 Charge Operating Current Limit			
	峰值限制 Peak Current Limit		持续限制 Continuous Current Limit	
	持续时间 Duration (sec)	I <sub>max_peak</sub> (A)	持续时间 Duration (sec)	I <sub>max_continuous</sub> (A)
55	30	212	持续	130
50	30	212	持续	130
45	30	212	持续	163
40	30	212	持续	163
35	30	212	持续	163
30	30	212	持续	163
25	30	212	持续	163
20	30	212	持续	163
15	30	163	持续	130
10	30	163	持续	130
5	30	163	持续	130
0	30	163	持续	130
-5	30	82	持续	49
-10	30	0	持续	0
-15	30	0	持续	0
-20	30	0	持续	0
-25	30	0	持续	0
-30	30	0	持续	0

## 3.2.3 安全电流限制 Safety current limit

温度 Temperature (°C)	安全电流限制 Safety current limit			
	放电 discharge		充电 Charge	
	I <sub>max</sub>	允许时间 Max. allowed duration	I <sub>max</sub>	允许时间 Max. allowed duration
	(safety)	(msec)	(safety)	(msec)
55	1.2*I <sub>max</sub>	1000	1.2*I <sub>max</sub>	1000
50	1.2*I <sub>max</sub>	1000	1.2*I <sub>max</sub>	1000
45	1.2*I <sub>max</sub>	1000	1.2*I <sub>max</sub>	1000
40	1.2*I <sub>max</sub>	1000	1.2*I <sub>max</sub>	1000
35	1.2*I <sub>max</sub>	1000	1.2*I <sub>max</sub>	1000
30	1.2*I <sub>max</sub>	1000	1.2*I <sub>max</sub>	1000
25	1.2*I <sub>max</sub>	1000	1.2*I <sub>max</sub>	1000
20	1.2*I <sub>max</sub>	1000	1.2*I <sub>max</sub>	1000
15	1.2*I <sub>max</sub>	1000	1.2*I <sub>max</sub>	1000
10	1.2*I <sub>max</sub>	1000	1.2*I <sub>max</sub>	1000
5	1.2*I <sub>max</sub>	1000	1.2*I <sub>max</sub>	1000

0	1.2*1 max	1000	1.2*1 max	1000
-5	1.2*1 max	1000	0	0
-10	1.2*1 max	1000	0	0
-15	1.2*1 max	1000	0	0
-20	1.2*1 max	1000	0	0
-25	1.2*1 max	1000	0	0
-30	1.2*1 max	1000	0	0

### 3.3. 温度限制 Temperature Limit

安全限制 Safety limit	最高存储温度 Max. storage	65°C	该温度为环境温度 This is to be ensured in an ambient temperature
	最低存储温度 Min. storage	-40°C	该温度为环境温度 This is to be ensured in an ambient temperature
	最高工作温度 Max. operation	65°C	该温度为电芯温度 This is to be ensured in a cell core temperature
	最低工作温度 Min. operation	-40°C	该温度为电芯温度 This is to be ensured in a cell core temperature
工作限制 Operation limit	最高工作温度 Max. operation	65°C	该温度为电芯温度 This is to be ensured in a cell core temperature
	最低工作温度 Min. operation	-36°C	该温度为电芯温度 This is to be ensured in a cell core temperature

## 4. 模组设计以及过程注意事项

### PARAMETER FOR MODULE DESIGN AND PROCESS

#### 4.1. 可施加在极柱上的最大扭矩 Max Torque which can be applied to terminal

扭矩强度：相切于极柱圆柱面 XY 方向最大 9Nm（2 小时）

Torque strength: tangent to the cylindrical surface of the pole, the maximum is 12 Nm in the XY direction (2 h)

#### 4.2. 可施加在极柱上的最大力 Max. Force which can be applied to terminal

1. 使用的 M6 螺栓在安装后与适配器啮合的深度不得超过 8mm。

（注意：使用大于 8mm 的螺纹螺栓，或者当它接触到螺栓插入开口的底部时，可能会导致脱落）

M6 bolts used may not engage the adaptor more than 8mm deep after installation.

(Note: using threaded bolts larger than 8mm, or when it touches the bottom of the bolt insert opening, may result in delamination).

2. 确保螺栓垂直且缓慢地拧入插件中，以避免使用任何剪切力。

Make sure the bolt is screwed vertically and slowly into the insert to prevent using any shear force.

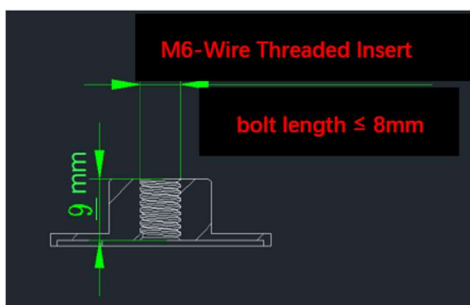

#### 4.3. 堆叠模组时大面挤压力 Large surface extrusion when stacking modules

大面挤压力：≤800 kgf

Large surface extrusion: ≤800 kgf

#### 4.4. 膨胀力 Swelling Force

1) 测试条件 Test condition

电池夹具：钢板

充放电条件

充电：1C, CC, 3.65 V, 0.05C 截止，静置 10 min

放电：1C, CD, 2.5 V, 静置 20 min

Cell Jig: steel plate

Charge/discharge condition

Charge: 1C, CC, 3.65 V, 0.05C cut off, rest 20 min

Discharge: 1C, CD, 2.5 V cut off, rest 20 min

2) 测试结果 Test result

单体电池膨胀力 Cell swelling force	BOL	< 3,000 N
	EOL	< 20,000 N

## 4.5. 模组焊接过程中温度的影响 Effect of Heat for Module Welding

### 4.5.1 允许焊接区域:

Allowable welding area

以极柱中心为圆心，直径大小 15 mm 的区域内。

In the area with the center of the pole as the center and diameter of 18 mm.

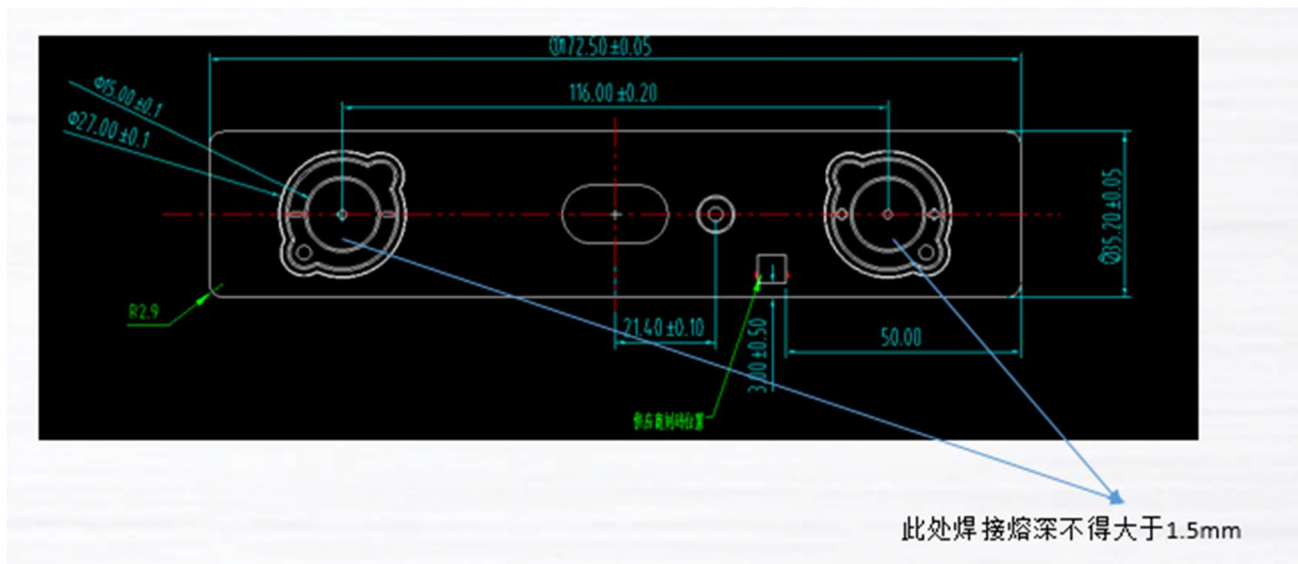

### 4.5.2 焊接对极柱高度的影响

Influence of welding on pole height.

焊接前后需要监测两个重要指标：极柱高度  $3.20 \pm 0.1\text{mm}$  以及极柱底面距离盖板光铝片底面距离  $2.00 \pm 0.05\text{mm}$ ，如下图所示。

Two important indicators need to be monitored before and after welding: the height of the pole is  $3.20 \pm 0.1\text{mm}$ , and the distance between the bottom of the pole and the bottom of the cover plate is  $2.00 \pm 0.05\text{mm}$ , as shown in the below figure.

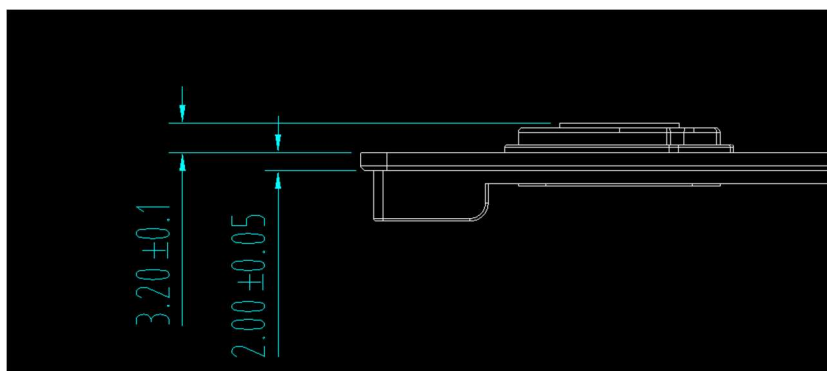

### 4.5.3 焊接过程中的温度边界:

Temperature boundary in welding process

焊接温度：焊接过程中，探测点 1 温度（极柱底部）不能超过  $120^\circ\text{C}$ ，探测点 2（极柱上塑胶边缘）不能超过  $60^\circ\text{C}$ 。

During welding, the temperature of detection point 1 (bottom of pole) shall not exceed  $120^\circ\text{C}$ , and that of detection point 2 (plastic edge on pole) shall not exceed  $60^\circ\text{C}$ .

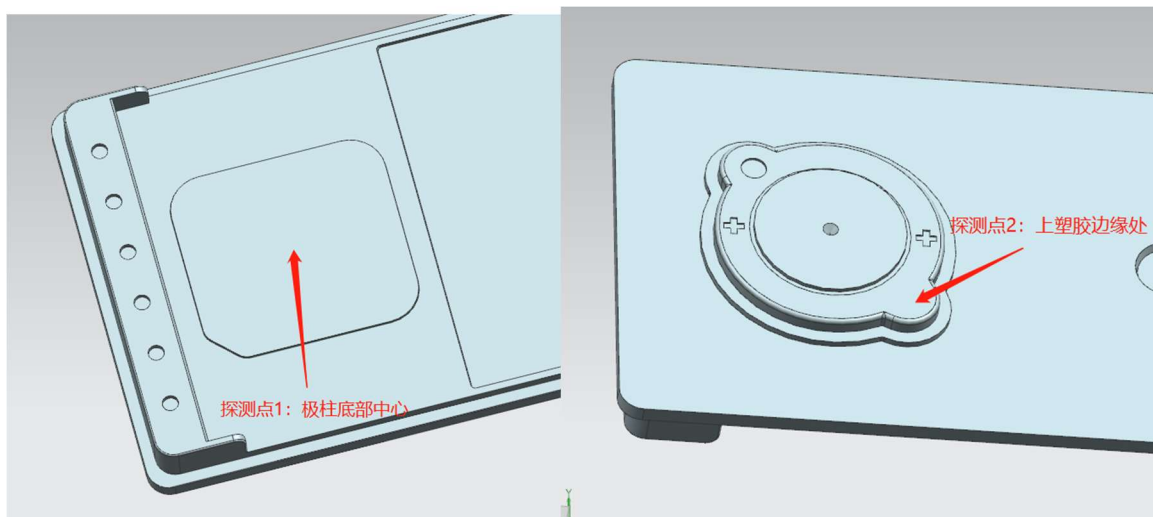

## 5. 危险警告、潜在故障 Hazard Warnings, Potential Faults

如果接触带电零部件，电弧会对生命和健康造成危险；

如果接触带电零部件，可能导致人员触电，并危害生命和健康（灼伤，心室纤维性颤动或者心跳停止）；

在失效情况下，可能泄露有机物质和酸类物质，并危害健康；

在过压，欠压后，在高温或高功率进行充放电时，会引起爆炸和起火的危险；

电解液等物质泄露，会对环境造成危害；

机械冲击危害：由于制造过程原因，电池外壳可能有锐边，因此需要特别注意。

Danger to life and health caused by an electric arc if active live parts are touched;

Danger to life and health (burns, ventricular fibrillation or heart stopping) caused by body currents if active live parts are touched;

Danger to health caused by organic substances and acids that might be emitted in case of failure conditions;

Danger of explosion and fire when operating with overvoltage, after under-voltage, at too high temperature or with too high charge or discharge power;

Environmental hazard from released substances, e.g. electrolyte;

Hazard by mechanical impact: the housing can have sharp edges due to manufacturing process, thus special care must be taken.

锂离子电池的一个特点是重量轻，能量高。在发生故障时，释放的热能相当于可使用能量的数倍。与正常的启动用铅酸电池不同的是，电解液不是水状的，而是有机的。电池是密封的，在正常工作中，气体，蒸气或液体不会漏出。

A characteristic feature of lithium-ion cell is a high energy content with a low weight. In the event of a fault, the thermal energy released is a multiple of the electrically usable energy. Unlike normal lead starter batteries, the electrolyte is not aqueous but organic. The cells are gas-tightened. In other words: No gases, vapors or liquids escape during normal operation.

不同于正常的启动用蓄电池，化学危害不是来源于酸和产生的氢气，而是来源于有机溶液、导电剂以及在发生故障时释放的二次化学反应物。发生故障的情况下，可能会释放有毒和腐蚀性的物质。

Unlike normal starter batteries, the chemical hazard is not from acids and the generation of hydrogen, but from organic solvents and the used conducting salt and their secondary chemical reactions when released in the event of a fault. Under faulty conditions, toxic and corrosive agents might be set free.

如果电池突然起火，由于电池内部既含有氧化剂又有还原剂，因此灭火剂的选择范围是有限的，只有大量的凉水能够用于灭火。这也可以冷却电池。

If the cell bursts into flames, the scope for extinguishing the fire is limited, as the battery cell contains both oxidants and reductive. Only cold water in large quantities should be used to extinguish the fire. This will also cool cells.

发生短路情况时，由于能量密度较高，电池会受到破坏，并可能产生电弧和熔融效果。这可能会导致冒烟，并释放有毒的腐蚀性物体（气体和液体）。

In case of a short circuit, cells will be damaged due to high energy content, stable electrical arcs and welding effects. This can cause smoke and the release of toxic and corrosive agents (gases and liquids).

如果接触到带电零部件（在发生故障的情况下，电池的金属外壳），对身体和健康具有危害性的电流会流经身体，并造成灼伤，心室纤维性颤动或者心跳停止。

If live parts (under faulty conditions, the metal housing of the cell) are touched, a current hazardous to life and health can flow through the body and may cause burns, ventricular fibrillation or even result in the heart stopping.

与电池接触时，应该小心。注意触电风险，以及发生事故时化学物品的危害。

Care should be taken during work with, at or inside the cells. Pay attention to the risk of electric shock and the hazard by chemicals in the event of an accident.

在进行与电池有关操作时，应至少两人在场。操作时，必须佩戴护目镜，以便发生意外时，能够提供帮助。电池仅能存放在合适的房间内。由于电池内部没有特殊的排气系统用以排放气体和电解液，所以当电池打开以后，一定要特别注意。

At least two people should be present in the room when working on cells. Eye contact must be kept through a glass panel so help can be given in the event of an accident. Cells may only be stored and operated in appropriate rooms. There is no special degassing system inside the cell for releasing gas and electrolyte in case of cell opening. Thus special care must be taken after cell opening.

对于有明显过热，机械冲击（掉落或跌倒）或者肉眼可见损坏的情况，电池不可以继续使用，并必须立即退回 CALB。

Cells that have clearly overheated, experienced mechanical shocks (fallen down or fallen over) or are visibly damaged cannot be used anymore but must be returned to CALB immediately.

可能发生故障的情景，原因和结果已如上所述。工作人员必须熟悉潜在的风险，保护措施和行为规范，并遵守。

Possible fault scenarios, causes and consequences are described in above statements. Each operator must be familiar with the risk potential, the protective measures and behavioral rules and observe them accordingly.

## 保护措施和行为规范 Protective Measures and Rules of Conduct

1) 由于电池具有较高电压（每一个电芯大于 3.65 V），因此在对电池进行相关操作时，尤其是带电的情况下，必须且仅能由具备动力电池基本知识的合格的电工进行，或者在合格的电工的管理和监督下进行此类工作。不得随意接近电池，进入实验室/测试床和电池储藏室应得到负责实验室管理者的批准和指示。

Work on this battery that has dangerous voltages (more than 3.65 V for each cell), particularly when it is live, must only be done by qualified electricians with basic knowledge of traction batteries or under the management and supervision of a qualified electricians qualified for such tasks. The cell must not be freely accessible. Access to laboratory/test bed and cell storage room should only be subject to approval and instruction from the responsible laboratory manager.

2) 进行与电池相关的工作时，必须穿戴个人防护用具（护目镜，绝缘手套，工作服，安全鞋和绝缘用具）。

Personal protective equipment must be worn when working on batteries (protective goggles, insulating gloves, work clothing, safety shoes and insulating tools).

3) 电池附近，拒绝火，火花，明火，易燃物体和吸烟。必须避免静电放电。务必须确保良好通风。在给电池充电时，应与易燃材料保持 2.5 m 的安全距离，以防止发生爆炸和起火风险。高度易燃材料绝对不能存放在电池室或测试实验室。

Fire, sparks, open flame, shouldering objects and smoking are prohibited near batteries. Electrostatic discharge must be avoided. Adequate ventilation must be ensured. When charging the cell, always maintain a safe distance of 2.5 m from flammable materials, as a risk of explosion and fire must generally be assumed. Highly flammable materials must not be stored in the cell room or test laboratory.

4) 锂离子电池中的电解液与导电盐可能具有毒性。在发生故障时，发生反应产品也可能具有腐蚀性。避免损害电池壳。当电池发生泄漏时，应立即使用酸性羊毛清理泄露的电解液，并置于废物处理容器中。

The electrolyte and the conducting salt from lithium-ion batteries can be toxic. Reaction products in the event of a fault may also be caustic. Avoid damage to battery housing. Clean up discharged electrolyte immediately with acid fleece and dispose in waste disposal container provided.

5) 仅能使用合适的吊装和运输工具，例如，升降装置符合 VDI3616。升降装置不可以损坏电池外壳和连接电缆。

Only use suitable and approved lifting and transport equipment, e.g. lifting gear compliant with VDI 3616. The lifting gear must not cause any damage to the battery housing or any connecting cables.

6) 一般来说，锂离子电池具有爆炸和起火风险。在发生故障时，电池的金属外壳可能带电。电弧或人体负荷电流会产生危害。不要将任何物体或工具放在电池之上。靠近电池时，必须取掉/拿掉戒指，手表，或衣服上的金属物件。

为进一步排除液体泄漏等危害，在从事电池相关工作或在测试台上时，禁止食用食物和饮料。

Generally lithium-ion batteries have a risk of explosion and fire. Warning! The metal housing of the cells may be live in the event of a fault (even in the discharged state). Danger from electric arc or body-borne current. Avoid short circuits! Do not place any objects or tools on the battery. Rings, wrist watches or any other metal parts on clothing must be taken off / removed when near to batteries.

In order to preclude any further potential hazards from leaking liquids etc., no drinks or food should be consumed while working on the cells or on the test bench.

## 5.1. 发生意外时的行动 Action in the Accidents

电解液接触皮肤：脱掉被污染的衣物。作为初步预防措施，清洗患处至少十五分钟。如果行动迅速，可以使用浓缩葡萄糖酸钙或葡萄糖酸钙凝胶，尽快通知医生。确定与空气中的水分反应是否可以产生 HF 和 CO，以及产生的量。确认涉及哪些有机电解液，需要采取哪些对策。

Electrolyte on the skin: remove contaminated clothing. Rinse affected area with water for at least 15 min as an initial precaution. If action is taken swiftly, calcium gluconate compressions or calcium gluconate gel can be applied. Inform your doctor. (Establish if and in what quantities HF and CO can be created as a result of reacting with moisture in the air. Establish which organic electrolyte is involved and what countermeasures are required).

电解液接触眼睛：立即使用微温自来水清洗至少 5 分钟。咨询眼科医生，他们将用局部麻醉剂冲洗，并用大量葡萄糖酸钙冲洗，并通知医生。

Electrolyte in the eyes: rinse immediately with lukewarm tap water for at least five minutes. Consult an ophthalmologist who will flush with local anesthetic and also rinse with plenty of calcium gluconate. Inform your doctor.

## 5.2 电池存储 Cell Storage

1) 存储区域务必保持干燥，尽可能没有灰尘，通风良好；

The storage area must be dry, as free of dust as possible and well ventilated;

2) 长时间存放应处于 20-25% SOC 状态；

Storage for prolonged period should be at 20–25% SOC;

3) 电池应存放在指定的电池房；

The cells may only be stored in a designated cell room;

4) 房间只能由授权人员进入；

Room must only be accessible to authorized persons;

5) 房间必须干燥通风；

Room must be dry and ventilated;

6) 将电池存放在电绝缘材料之上；

Store the cells on surfaces that provide electrical insulation;

7) 应避免静电放电；

Electrostatic discharge must be avoided;

8) 允许的温度区间：-36°C-65°C，推荐温度为-20-25°C；

Permissible temperature range: -36°C–65°C; temperatures -20-25°C are recommended;

## 5.3 注意事项 Attention

只有在与授权电工协商并获得其批准的情况下，才允许由授权的电工自主操作电池。电池系统的结构特点，状态，电池组与电池测试台的连接-必须事先由合格的电工检查。如果几名员工在一台测试台上工作，须指定一名工作管理者。



Autonomous operation of cells by an electrician qualified for certain tasks instructed in the operation of cells is only permissible subject to consultation with and approval by a qualified electrician! The structural features — cabling, state of the battery pack system, connection of the same to the battery test bench — must be checked by the qualified electrician in advance. If several employees are working on one test bench, a work manager must be designated.

工作管理者负责确保按照 5 项安全规则开展工作：

The work manager is responsible for ensuring that the work is carried out in conformity with the five safety rules:

断开连接 Disconnect

防止意外重启/重合闸 Provide a safeguard to unintentional restart/reclosing

确保零电位 Assure zero-potential

检查接地和短路 Ground and short-circuit

遮盖相邻带电部件 Cover or shield neighboring live parts

通常，只有在检查了所有系统的电缆和连接以及设置之后，才能激活电池和测试台。连接和电缆必须牢固布线并防止接触。只有合适的电池测试台可以用于电池充放电。

As a rule, activation of the cells and/or the test bench is only permitted once the cabling and connections and the settings of all systems have been checked! Connections and cabling must be securely routed and protected against contact. Only a suitable battery test bench may be used to charge or discharge cells.

在通风良好的房间内，可为电池进行充电，在可自由出入的地方充电时，必须封闭电池，并在适当的地方张贴清晰可见的警告标志。必须用安全链封锁测试站，以防止不参与测试工作的人员无意中接近组件的带电部件。基座的位置必须确保与测试组件带电部件的最小距离。

Cells may only be charged in rooms with adequate ventilation — see also protective measures and rules of conduct. When charging in freely accessible areas, the cells must be blocked off and a clearly visible warning sign should be put up where appropriate. The test station must be cordoned off with a safety chain to prevent persons not involved with the work on the test bench inadvertently approaching live parts of the assembly. The pedestals of the chain must be positioned so that the minimum distances from the live parts of the test assembly are met.

测试期间，低压电源接通的地方，仅直接参与测试人员可停留在测试站划定的区域。其他人员必须离开测试区域。耐久试验只能在特别设计的，带自动关闭，灭火系统和通风装置的电池测试台上进行，测试台在运行过程中不受监督。在充电过程中，必须实时监测电池状态。

During tests where the low voltage supply is switched on, only those persons directly involved with the tests may stay within the demarcated area of the test station. Other persons must leave the test area. Endurance tests where the test bench remains unsupervised during operation are only permitted on specially designed cell test benches with automatic switch-off, an extinguisher system and ventilation. The cell status must be monitored constantly during charging.

电池处置必须考虑当地规定。

The cell must be disposed considering local regulations.

## 5.4 注意和禁止事项 Caution and Prohibition

锂离子电池装卸不当会导致漏液，发热，冒烟，爆炸或起火，但可能会引起性能劣化或发生故障。请认真遵守说明进行操作。

Improper handling of lithium ion cell may cause leakage, heat, smoke, explosion, or fire. This could cause deterioration of performance or failure. Please be sure to follow instructions carefully.

### 安全注意和禁止事项 Safety precautions and prohibitions

为确保产品安全，请在应用说明手册中列出以下注意事项。

To assure product safety, please list the following precautions in the application's instruction manual.

## 电气误用 Electrical misuse

-使用专用充电器

Use dedicated charger

-仅在专业应用中使用或给电池充电

Use or charge the battery only in the dedicated application

-禁止反向充电

Reverse charging is prohibited

-充电电流必须控制在电池规格书中的指定值；

Charge current must be controlled by the specified value in the cell specifications

-充电截止电压必须为 3.65 V；

Cut-off voltage for charging must be 3.65 V

-检测到电池规格书中指定的截止电流时，充电器必须停止给电池充电；

Charger must stop charging battery by detecting cut-off current specified in the cell's specifications

-放电电流必须控制在产品规格书中的指定值；

Discharge current must be controlled by the specified value in the product specifications

-当温度在 0°C 以下时，放电截止电压必须在 2.0V 以上；

Cut-off voltage of discharging must be over 2.0 V when the temperature is below 0°C

## 环境误用 Environmental misuse

不要将电池置于火源或热源附件

Don't leave a cell near a fire or a heat source

不要将电池扔在火中

Don't throw a cell into a fire

不要把电池浸泡，投掷，或者浸湿在水中

Don't immerse, throw, and wet cell in water / seawater

其他 Others

不要在电池附件存储金属物件（例如钥匙，螺丝刀）

Don't store metallic objects (such as keys or screwdriver) near the cell.

不要故意使用金属器件将正负极短路

Don't short circuit (+) and (-) terminals with metallic object intentionally.

不要使用尖锐物体，比如针或螺丝刀刺穿电池

Don't pierce cells with a sharp object such as a needle, or screwdrivers.

不要使用加热物体，比如烙铁，加热电池的部件

Don't heat a part of cells with heating objects such as a soldering iron.

不要使用重物，比如锤子击打电池；

Don't hit cells with heavy objects such as a hammer, or heavy weights.

不要踩踏电池，或将电池投掷，或掉落在硬地面上；

Don't step on cells, or throw or drop a cell on the hard floor.

不要拆解电池，或者修改电池设计，包括电路；

Don't disassemble a cell or modify the cell design including electric circuit.

不要直接在电池上焊接任何东西；

Don't solder anything on cells directly.

不要使用严重刮划或变形的电池；

Don't use seriously scratch or deform cells.

不要将电池放在微波炉，烘干机，或高压容器之中；

Don't put the a cell into a microwave oven, dryer, or a high-pressure container

不要拆解电池；

Don't disassemble cells.

不要暴露于水溅条件；

Don't expose to water splashing condition.

不要暴露于极度潮湿的条件下；

Don't expose to heavy humidity condition.

电池发生坠落事件后，不要使用；

Don't use after drop accident.

使用充电器前，确保阅读充电器用户手册；

Before using charger, be sure to read the charger's user manual.

在将电池安装到应用或拆除之前，确保阅读应用用户手册。

Before installing and removing cells from application, be sure to read the application's user manual.

如果电池需要储存很长一段时间，那么应将电池从应用上移除，在室温条件下，存放在室温条件下适当的地方，并考虑前述合适的放置期间（20% SOC，12个月）。

If cell needs to be stored for a long period, cells should be removed from the application and stored in a proper place under room temperature conditions and consider the described available leaving period (12 months at 20% SOC). While the cell is charged, used and stored, keep it away from object materials with static charge.

## 警告 Warning

如果在指定时间内未完成充电，则停止充电。

Stop charging cells if charging isn't completed within the specified time.

如果电池变得异常发热，产生异味，变色，变形，或者在使用，充电，放电或存储期间发生其他异常情况，停止使用电池。

Stop using cells if the battery becomes abnormally hot, develops an odor, becomes discolored, deformed, or develops any other abnormal conditions during use, charge, discharge, or storage.

当检测到漏液或产生恶臭时，立即远离火源和热源。如果液体泄漏接触到皮肤或衣物，立即使用大量清水进行清洗。如果电池泄漏液体接触到眼睛，切勿揉搓眼睛。用大量清水洗净眼睛并立即就医。

Keep away from fire or hot heat sources immediately when a leakage or foul odors are detected. If liquid leaks onto your skin or cloths, wash it out with plenty of fresh water immediately if liquid leaks from cells and gets into your eyes, don't rub your eyes. Wash your eyes out with plenty of clean water and seek medical attention immediately.

如果电池端子变脏，则使用电池之前用干布擦拭干净。

If the terminals of cells become dirty, wipe them with a dry cloth before using the cells.

电池只能在以下温度范围内使用。不要超过此温度范围。

Cells can be used within the following temperature ranges. Don't exceed these ranges.

使用前，用适当的绝缘胶带覆盖极柱。

Cover terminals with proper insulating tape before disposal.

放电截止（2.5 V）后，不要将电池放置6个月以上。

Don't leave cells over 6 months after discharging cut-off (2.5 V).

长时间储放和放置后，如果不能充电和工作，则停止充电和工作，并联系客服中心。

After long storage and leaving period, if charging and operating is not available, stop the charging and operating, contact the service center.

## 附录 Appendix

### 1. 温度循环试验：单次循环的温度和时间

Temperature cycle test: temperature and time for single cycle

温度 (°C)	时间增量 (min)	累计时间 (min)	温度变化率 (°C/min)
25	0	0	0
-40	60	60	13/12
-40	90	150	0
25	60	210	13/12
85	90	300	2/3
85	110	410	0
25	70	480	6/7

### 2. 温度循环试验示意图

Schematic diagram of temperature cycle test

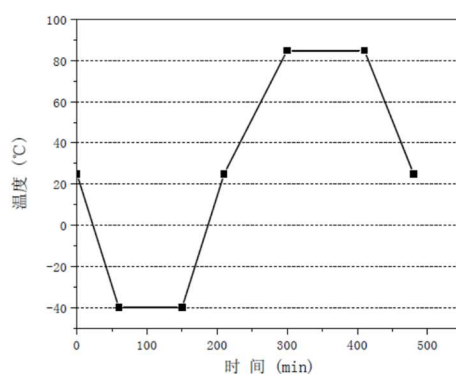

### 3. 加热装置功率选择

Power selection of heating device

测试对象能量 E (Wh)	加热装置最大功率 (W)
$E < 100$	30~300
$100 \leq E < 400$	300~1000
$400 \leq E < 800$	300~2000
$E \geq 800$	>600

### 4. 加热触发时温度传感器的布置位置示意图

Schematic diagram of temperature sensor layout when heating is triggered

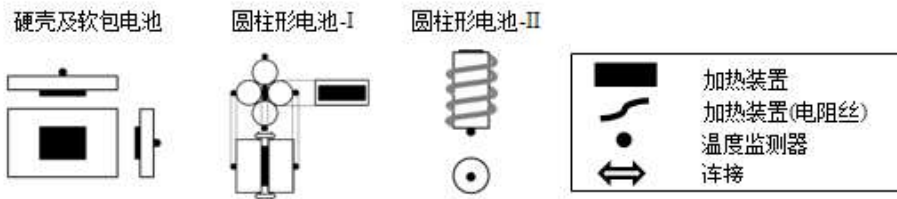

## 5. 振动测试参数

Vibration test parameters

振动激励	宽带噪音
各空间轴的试验持续时间	8h
加速度有效值	30.8m/s <sup>2</sup>
频率 HZ	功率密度频谱 (m/s <sup>2</sup> ) <sup>2</sup> /HZ
5	0.884
10	20
55	6.5
180	0.25
300	0.25
360	0.14
1000	0.14
2000	0.14

## 6. 振动曲线

Vibration curve

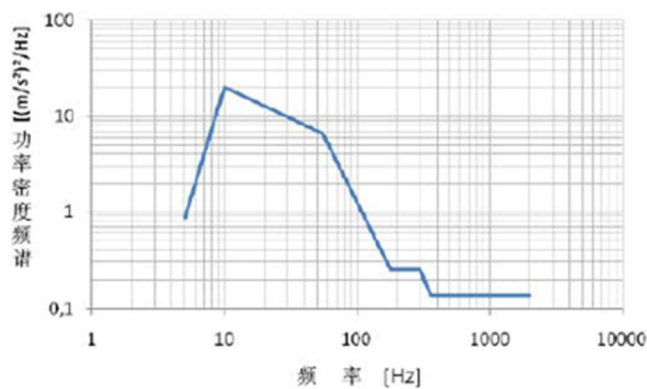

## 7. 温度参数

Temperature parameters

